

# PRE-RENTAL CHECK OFF LIST ROUGH TERRAIN SCISSOR LIFT

CUSTOMER NAME/ CONTRACT NUMBER \_\_\_\_\_

Customer Initials: \_\_\_\_\_ INITIALS INDICATE CUSTOMER HAS BEEN SHOWN OPERATION OF LIFT AND IS CONFIDENT OF OPERATION OF LIFT AND OPERATION MANUAL IS ON LIFT.

Employee Initials: \_\_\_\_\_

HAVE PICTURES BEEN TAKEN? YES / NO

IF NO PICTURES TAKE CIRCLE AND INDICATE AREAS OF DAMAGE

LEFT SIDE OF LIFT

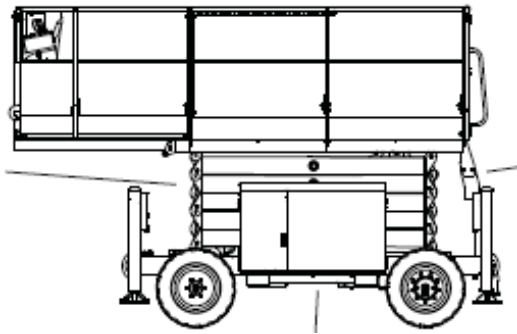

RIGHT SIDE OF LIFT

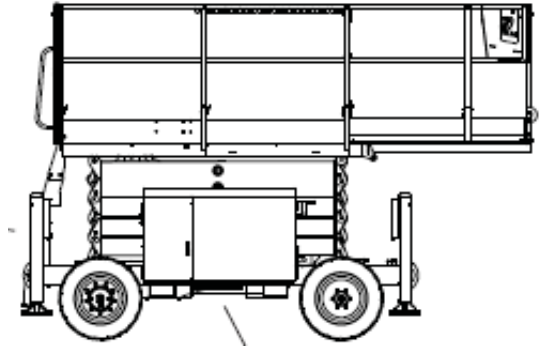

FRONT

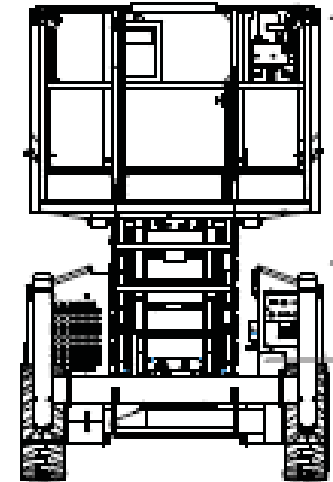

BACK

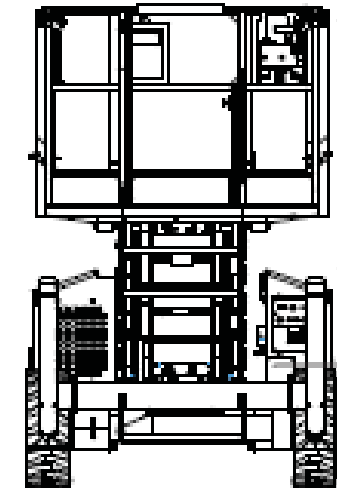

FULL OF DIESEL \_\_\_\_\_ CHECK OIL \_\_\_\_\_ VISUAL INSPECTION \_\_\_\_\_

PLEASE CHECK OFF ITEMS AS INSPECTED  
HAVE CUSTOMER AND ABC STAFF MEMBER INITIAL FORM AND RETURN TO FRONT DESK



# CUSTOMER'S COPY

## SAFETY AND OPERATION MANUAL FOR SNORKEL ROUGH TERRIAN SCISSOR LIFT



SCAN FOR COMPLETE OPERATION MANUAL

(MOBILE DEVICE WITH QUICK RESPONSE CODE APPLICATION  
REQUIRED)

